



LET'S PLAY FLUTE

QUICK START GUIDE

- Getting started
- Fun Tunes
- Fingering Chart

Brittany Bauman
Antonio Lao

NUVOBand
■ ■ ■ ■ ■

PRACTICE JOY

We are thrilled that you decided to buy a **NUVOBand** FLUTE and if it's the beginning of your musical journey, we know it has the potential to change your life.

Music is a language. It connects us all and has the capacity to generate deep emotions. Love, joy, ecstasy or sorrow and everything in between. Just a few carefully chosen notes can induce intense emotions. There are, of course, other modes of universal human connection such as literature, film, food, and cultural traditions but music is perhaps the perfect accompaniment and conduit for all forms of connection.

Whether you are a complete beginner at the start of your journey or an accomplished musician, we hope you will enjoy the benefits of practicing often with your **NUVOBand** FLUTE. We designed it to make practicing easy and joyful. It's lightweight and durable so we encourage you to keep it out and practice often. Research shows that frequent short practices result in faster overall progress. You will be able to focus more intensely for short periods and you will likely practice more frequently if your instrument is out and ready to go whenever the mood grabs you!

We want to share in your journey so please feel free to reach out and show us what you have accomplished. It can get very dry working on the engineering aspect of our instruments so it fills us with joy to hear how people all over the world are making music with them.

Finally, we care about the impact of our products on our environment. Our instruments are designed to last forever and will take some knocks along the way. If you decide to move on from the **NUVOBand** family, please pass your instrument on to someone else who can enjoy the benefits. In the meantime, reach out to us if you ever need a spare part or some technical advice. You can register for your parts warranty which lasts for 5 years from the instrument's "birthday". After that, parts are readily available to purchase in most parts of the world and most problems can be easily fixed. See the "Repairs and Maintenance" page on our website.

Thanks for joining the **NUVOBand** family and keep practicing...it will be worth it!

A handwritten signature in black ink that reads "Max". The letter "M" is tall and has a long vertical stroke that extends downwards. The "a" and "x" are smaller and more compact.

Contents

	Page
Meet the FLUTE	3
Care and Maintenance	4
Repairs	5
Parts of the FLUTE	6
Full Instrument Assembly/Key Covers	7
Holding the FLUTE	8
Playing Position	9
First Sounds: Embouchure	10
Articulation	11
Flute Fingering Chart	12
Let's Improvise	13
Track 1: Rock and Roll.....	
Track 2: Hip-Hop.....	
Track 3: 12 Bar Bles.....	
Track 4: Percussion.....	
Track 5: Classic Film.....	
Track 6: Latin Inspired.....	
Music Notation	14
Notes C and D	15
Tunes:	
Track 7: Solo Me.....	16
Track 8: Au Clair de la Lune.....	17
Track 9: Jig Saw.....	18
Track 10: Easy Rapper.....	19
Track 11: Funky Latin.....	20
Track 12: London Bridge.....	20
Track 13: Oh When the saints.....	21
Track 14: Jingle Bells.....	22
Track 15: Rainbow.....	23
Introducing Eighth Notes	24
Track 16: Jumping Jack.....	25
Track 17: African Safari.....	26
Full Fingering Chart	27-29

Meet the FLUTE

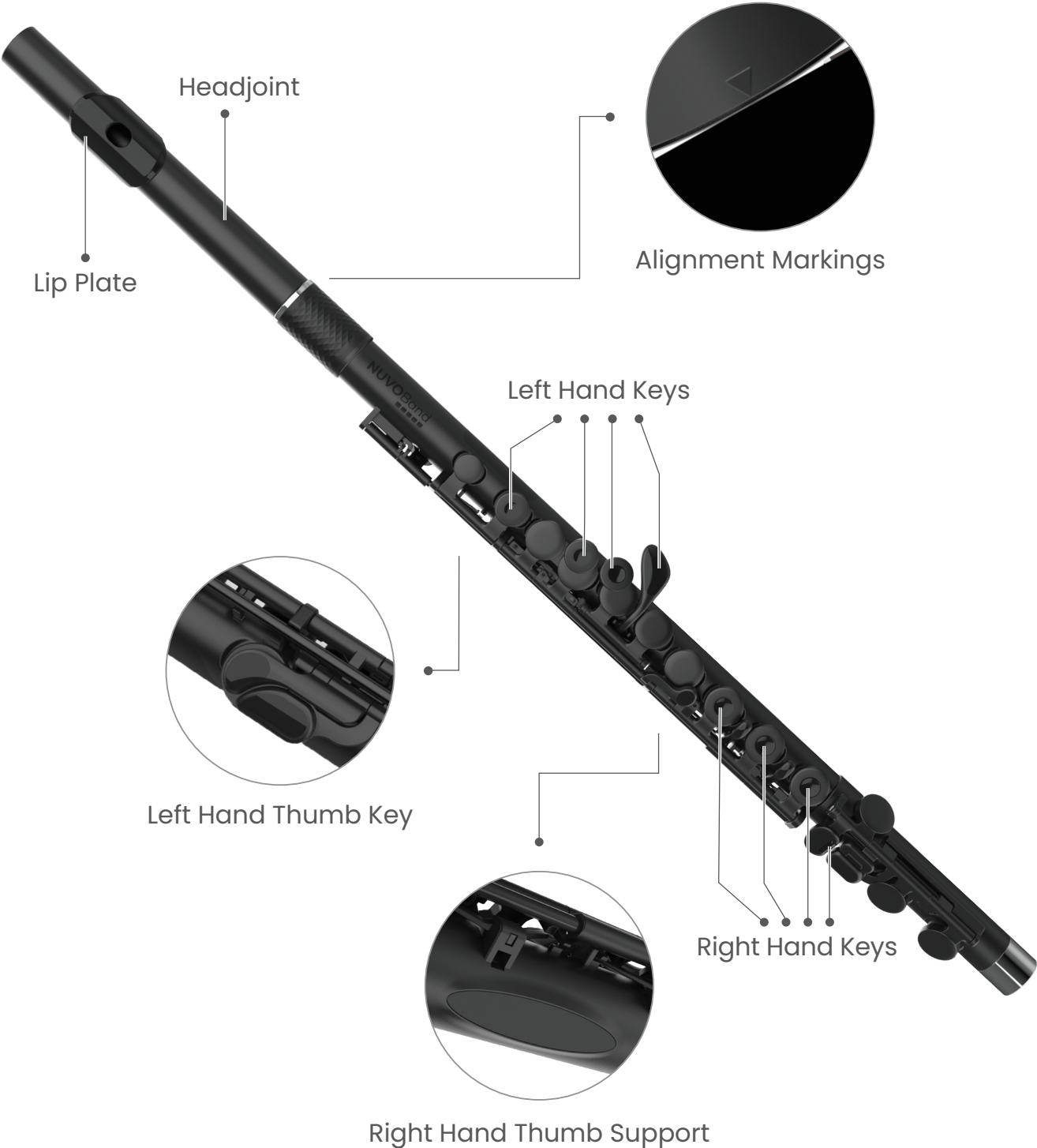

FLUTE Fingering Chart

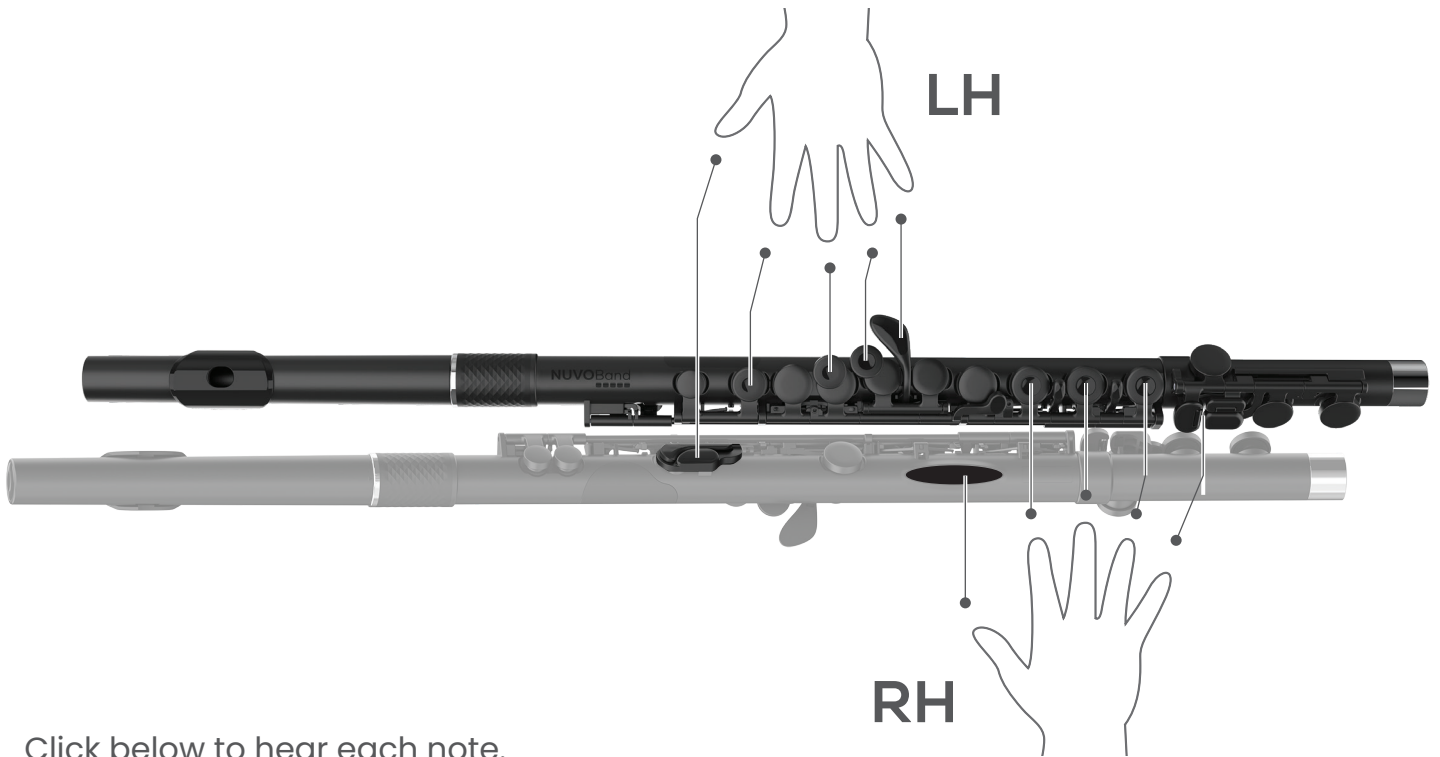

Click below to hear each note.

 G		 D	
 A		 E ^b	
 B ^b		 F	
 C			

The full fingering chart can be found on the **NUVOBand** website: www.nuvoband.com.

Let's Read Some Notes: C and D

Remember, the fingering charts are from the perspective of the player!

NOTE C 



NOTE D 

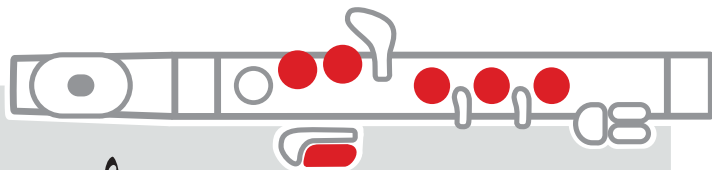

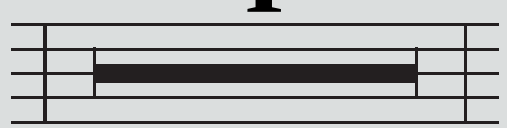

Notice that note C sits between two lines. We call this a "space". Note D is different and has a line through the middle of the note.

4



Multi-measure rest:
Means rest for four full measures

,

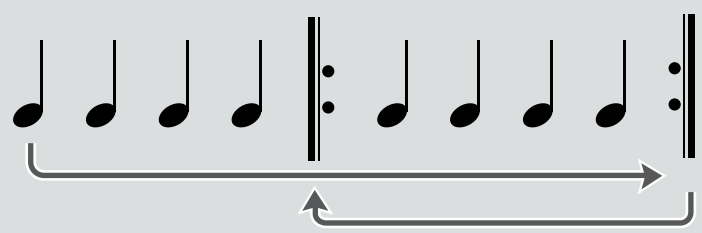

Breath Mark:
Show good places to take a breath.

4/4 

Repeat signs mean play it again!

Let's Play Some Tunes

Now that you are comfortable with some notes, let's try some new and familiar tunes.



Listen to the track before playing this piece. Practice moving your fingers to the different notes while listening/singing along with the recording.



Solo Me

Paul Barker

♩ = 100

4
1-4

5
mf

9

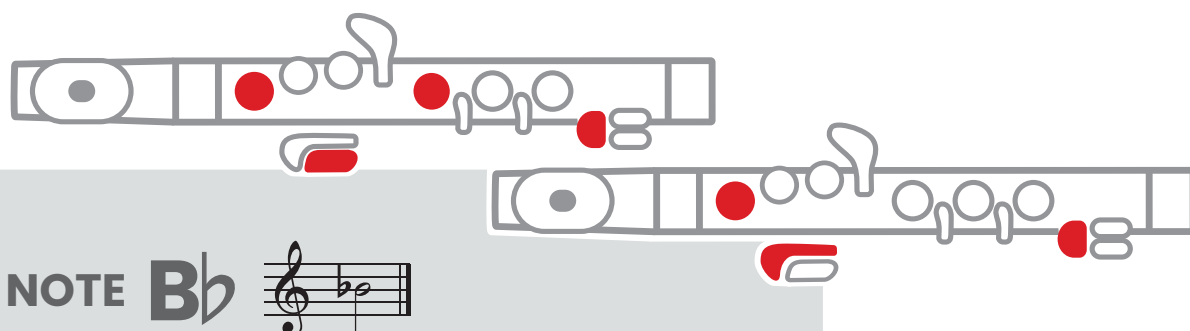

Try singing the melody before you play. You can sing on a neutral syllable like "bah".



Au Clair de la Lune

Arr. Paul Barker

$\text{♩} = 100$

2

1-2

3

mf

7

Keep it out!



Explore the rest of the
LET'S PLAY series.

LET'S PLAY

www.nuvoband.com

Brittany Bauman
Antonio Lao

NUVO
Band

Tailor-made for Practice